



710PT-U Pinch Tube Valve Operating Manual

info@fisnar.com

www.fisnar.com

OPERATING MANUAL INTRODUCTION**710PT-U PINCH TUBE VALVE**

The PINCH TUBE VALVE provides a wide degree of control for continuous or micro shot applications of low to semi-viscous fluids.

The “ON/OFF” control is achieved by automatically pinching a molded polyethylene tube assembly. The degree to which the tube assembly is pinched determines the flow rate. The air-powered valve can be timed to produce the desired shot size. A wide range of needle tips can be used to further refine the amount of fluid dispensed.

The disposable tube assembly is the only component that will be exposed to the dispensed fluid.

The valve design prevents rotation of the “SHUT-OFF” blade, allowing the use of a narrow chisel point head on the “SHUT-OFF” piston. This design provides the fine degree of control necessary to make precise shots.

The valve operates by connecting the air piston (8) to the “SHUT-OFF” piston (1) with two push rods, which pass on either side of the pinch tube (6).

Adjustment of knob (4) controls the travel of the “SHUT-OFF” piston by limiting its reverse movement. The “SHUT-OFF” piston is moved by the push rods on the air piston.

The travel of the “SHUT-OFF” piston determines the amount of opening for the dispense tube and, when coupled with a time control, determines the shot size.

PRODUCT DESCRIPTION

710PT-U PINCH TUBE VALVE

OPERATION PROCEDURE

The valve will operate in any position, providing the supply source is pressurized. If gravity feed is being used, the inlet side of the valve must be in an upright, vertical position and the reservoir must always be six inches above the center line of the valve. Gravity supply will work only with very thin pourable materials.

A threaded mounting hole in the side of the body accepts a mounting rod (25).

The valve requires a minimum of 60 psi to properly operate the opening piston. The shut-off function is achieved by an internal spring.

The air line to the valve should be attached to a three-way air supply valve (manual or automatic). Actuating this valve will open the pinch tube valve. The open time determines the shot size.

If using a remote reservoir, use the enclosed supply line (20, 21) to provide a connection point to the pinch tube (17-19) fluid inlet. A syringe barrel can be mounted directly to the pinch tube fluid inlet.

BE SURE ALL AIR HAS BEEN BLED FROM THE SUPPLY LINE TO OBTAIN REPEATABLE SHOT SIZES OR UNINTERRUPTED FLOW.

NOTE: if material drips from the needle tip, follow instructions below

- A. Fully close the adjustment knob (4) to form a “crease” in the pinch tube.
- B. Operate the valve and slowly open the adjustment knob until material comes out from the tip.
- C. Adjust the knob position per flow rate requirement.
- D. Tighten the lock nut (15) to secure the flow rate adjustment.

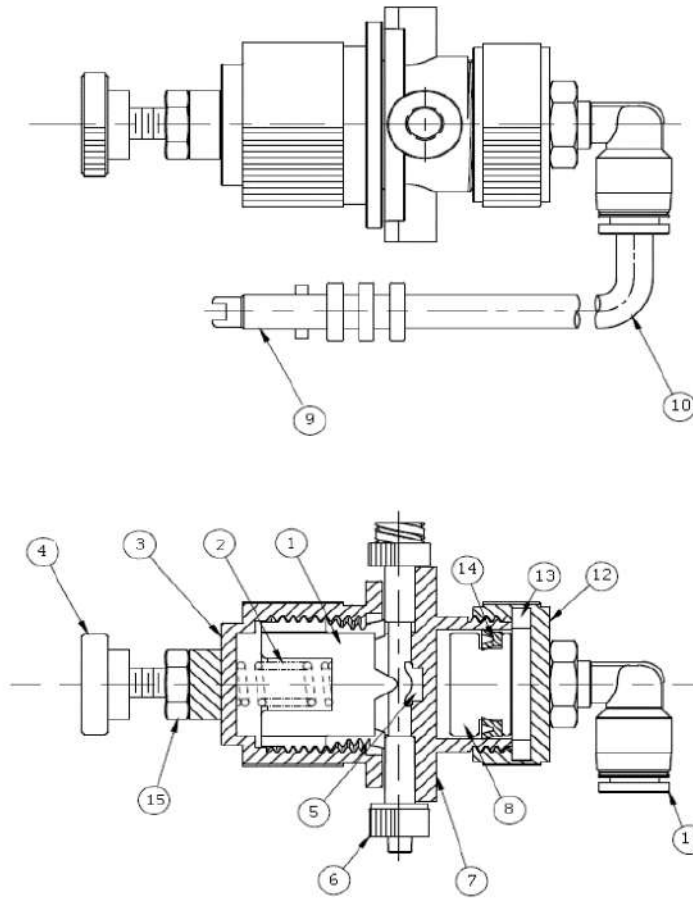

No	PART NUMBER	DESCRIPTION	QTY	No	PART NUMBER	DESCRIPTION	QTY
1	580025U	Shut-Off Piston	1	14	580031U	U-cup Seal	1
2	580028U	Spring	1	15	580036U	Lock Nut	1
3	580024U	Flange	1	16*	5601062	Hose Clamp	1
4	580029U	Adjustment Knob	1	17*	580037A	Pinch Tube .10" ID x 1.74 - Natural	3
5	580026U	Pinch Cushion	1	18*	580037A-BLACK	Pinch Tube .10" ID x 1.74 - Black	3
6	(See 17*, 18*, 19*)	Pinch Tube		19*	580038A	Pinch Tube .07" ID x 1.74 - Natural	3
7	580022U	Valve Body	1	20*	580047A-10-24	Fluid Line PE .10" ID x 24" - Natural	1
8	580027U	Air Piston	1	21*	580047A-BLK-10-24	Fluid Line PE .10" ID x 24" - Black	1
9	5601064	Male Quick Connect	1	22*	5601390	Luer Lock Adapter - Natural	1
10	560705-10FT	PU Tubing .145" ID x 1/4" OD	1	23*	5801449	Luer Lock Adapter - Black	1
11	561964	Push-In Connector 1/4" Tube	1	24*	QK-NSK	Needle Selection Kit	1
12	580023U	Cylinder Cap	1	25*	580033-LF	Rod Mount	1
13	580030U	Gasket	1				

*Included Accessories, not shown on diagram.



info@fisnar.com

www.fisnar.com